

# Tech Bulletin

## BH/CH/EH37000

### Conversion Kit & Requirements

Customers seeking to upgrade to the heavy duty BH/CH/EH37000 from earlier models can refer to the kit detailed in this tech bulletin. The kit utilizes a ductile iron spindle, gooseneck and full through shaft for additional support. The fluid path is a full flow 1" ID. New design incorporates a fully wrapped drum and oil lite bearings in favor of the previous self-aligning bearings.

#### Bevel Crank BH37000

S602600-18

S602600-22

S602600-28

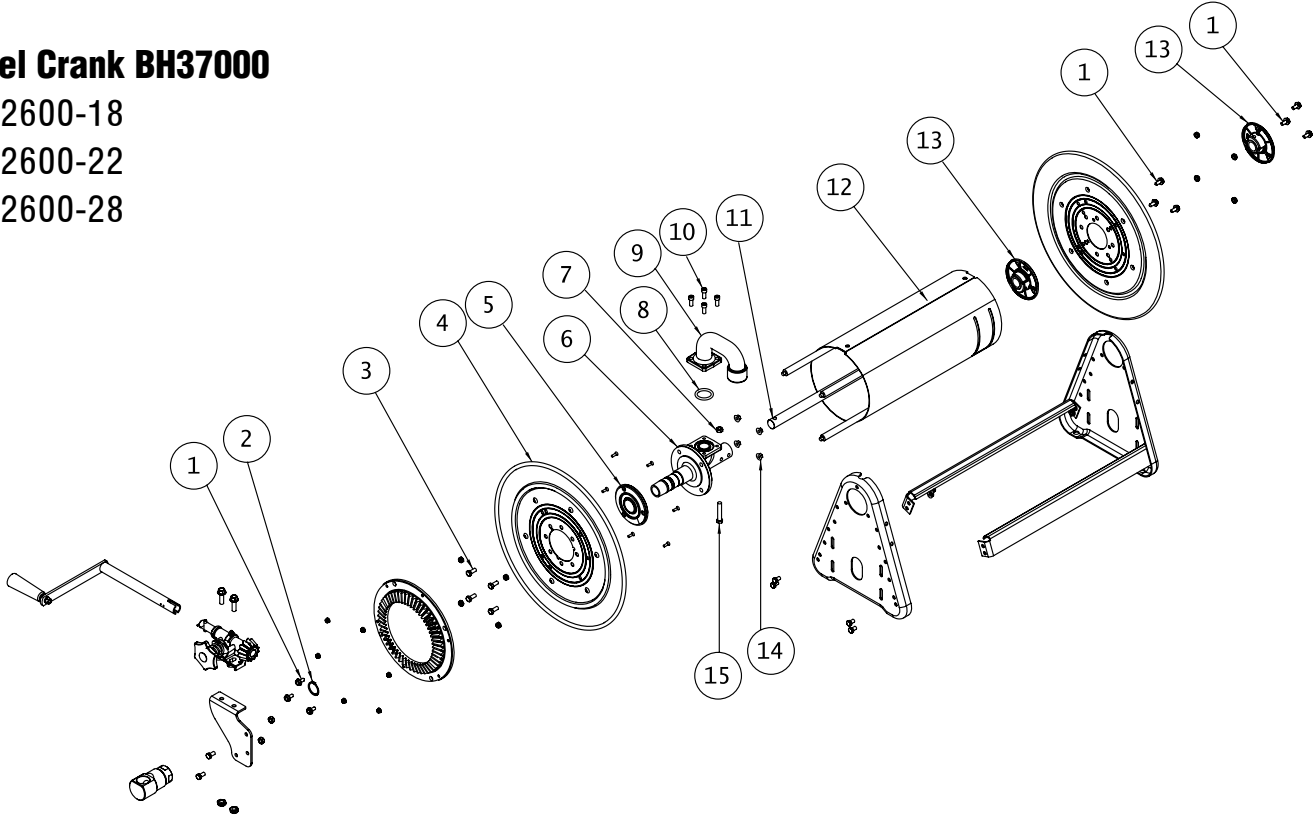

#### Parts included in kit

No.	Qty.	Part No.	Description	No.	Qty.	Part No.	Description
1	9	S317-31	5/16-12 Self Tapping Screw	9	1	262455-INPT	Gooseneck
2	1	S140-31	1-5/16 Snap Ring	10	4	S7-51	5/16-18 Socket Head Cap Screw
3	4	S2-53	5/16-18 Hex Head Cap Screw	11	1	See Chart 2	
4	1	262650	Spool Flange	12	1	See Chart 2	
5	1	602588	Hub & Bearing Assembly	13	2	602587	Hub & Bearing Assembly
6	1	262454	Spindle	14	4	261650-2	5/16-18 Hex Head Lock Nut w/ Nylon Insert
7	1	S85-7	3/8-16 Nyloc Nut	15	1	S376-59	5/16-18 Grade 8 Cap Screw
8	1	S200-324	O-Ring				

Kit No.	Model No.	No.	Qty.	Part No.	Description
S602600-18	BA/BB37118 L	11	1	262659-18	Support Shaft
S602600-18	BA/BB37118 L	12	1	326100-18X18-4	Drum
S602600-22	BA/BB37122 L	11	1	262659-18	Support Shaft
S602600-22	BA/BB37122 L	12	1	326100-22X18-4	Drum
S602600-28	BA/BB37128 L	11	1	262659-18	Support Shaft
S602600-28	BA/BB37128 L	12	1	326100-28X18-4	Drum

Form # TB0038 Rev: 9/2013

Customers seeking to upgrade to the heavy duty BH/CH/EH37000 from earlier models can refer to the kit detailed in this tech bulletin. The kit utilizes a ductile iron spindle, gooseneck and full through shaft for additional support. The fluid path is a full flow 1" ID. New design incorporates a fully wrapped drum and oil lite bearings in favor of the previous self-aligning bearings.

**Hand Crank CH37000**

- S602600-18
- S602600-22
- S602600-28

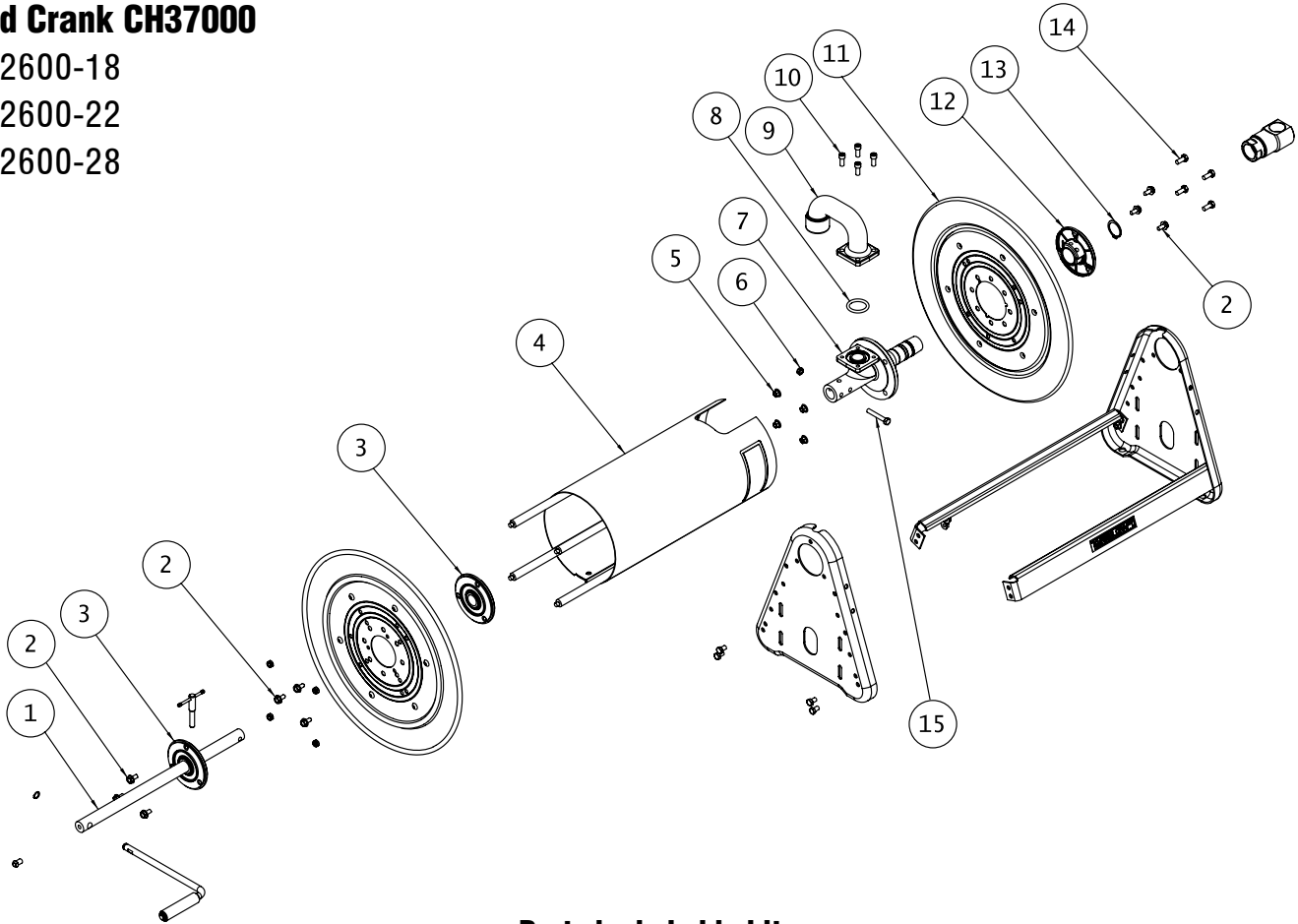

**Parts included in kit**

No.	Qty.	Part No.	Description	No.	Qty.	Part No.	Description
1	1	See Chart 2		8	1	S200-324	O-Ring
2	9	S317-31	5/16-12 Self Tapping Screw	9	1	262455-INPT	Gooseneck
3	2	602587	Hub & Bearing Assembly	10	4	S7-51	5/16-18 Socket Head Cap Screw
4	1	See Chart 2		11	1	262650	Spool Flange
5	4	261650-2	5/16-18 Hex Head Lock Nut w/Nylon Insert	12	1	602588	Hub & Bearing Assembly
6	1	S85-7	3/8-16 Nyloc Nut	13	1	S140-31	1-5/16 Snap Ring
7	1	262454	Spindle	14	4	S2-53	5/16-18 Hex Head Cap Screw
				15	1	S376-59	5/16-18 Grade 8 Cap Screw

Kit No.	Model No.	No.	Qty.	Part No.	Description
S602600-18	CA/CB37118 L	1	1	262659-18	Support Shaft
S602600-18	CA/CB37118 L	4	1	326100-18X18-4	Drum
S602600-22	CA/CB37122 L	1	1	262659-22	Support Shaft
S602600-22	CA/CB37122 L	4	1	326100-22X18-4	Drum
S602600-28	CA/CB37128 L	1	1	262659-28	Support Shaft
S602600-28	CA/CB37128 L	4	1	326100-28X18-4	Drum

Customers seeking to upgrade to the heavy duty BH/CH/EH37000 from earlier models can refer to the kit detailed in this tech bulletin. The kit utilizes a ductile iron spindle, gooseneck and full through shaft for additional support. The fluid path is a full flow 1" ID. New design incorporates a fully wrapped drum and oil lite bearings in favor of the previous self-aligning bearings.

**Motor Driven EH37000**

- S602600-18
- S602600-22
- S602600-28

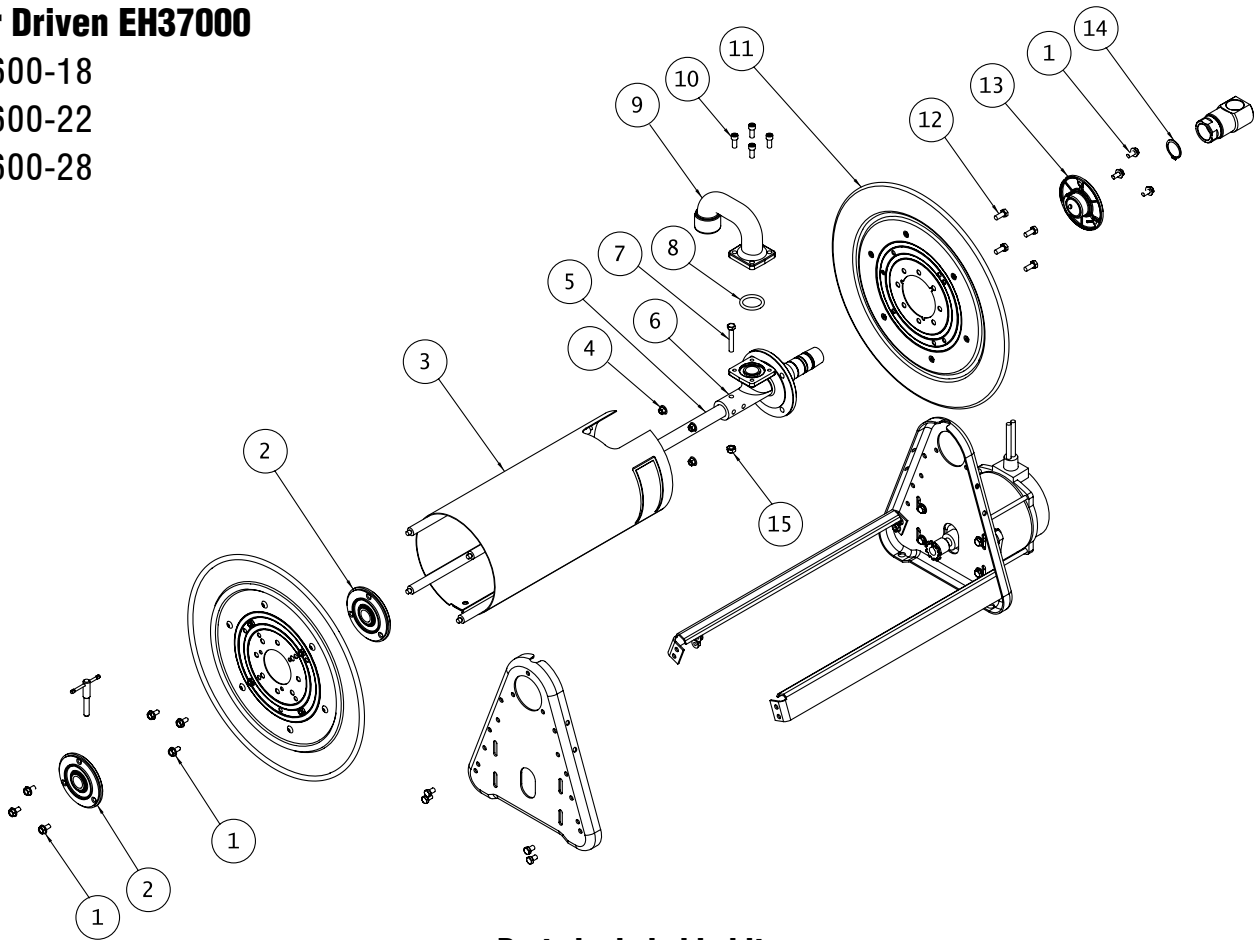

**Parts included in kit**

No.	Qty.	Part No.	Description	No.	Qty.	Part No.	Description
1	9	S317-31	5/16-12 Self Tapping Screw	8	1	S200-324	O-Ring
2	2	602587	Hub & Bearing Assembly	9	1	262455-INPT	Gooseneck
3	1	See Chart 2		10	4	S7-51	5/16-18 Socket Head Cap Screw
4	4	261650-2	5/16-18 Hex Head Lock Nut w/Nylon Insert	11	1	262650	Spool Flange
5	1	See Chart 2		12	4	S2-53	5/16-18 Hex Head Cap Screw
6	1	262454	Spindle	13	1	602588	Hub & Bearing Assembly
7	1	S376-59	5/16-18 Grade 8 Cap Screw	14	1	S140-31	1-5/16 Snap Ring
				15	1	S85-7	3/8-16 Nyloc Nut

Kit No.	Model No.	No.	Qty.	Part No.	Description
S602600-18	EA/EB37118 L	5	1	262659-18	Support Shaft
S602600-18	EA/EB37118 L	3	1	326100-18X18-4	Drum
S602600-22	EA/EB37122 L	5	1	262659-22	Support Shaft
S602600-22	EA/EB37122 L	3	1	326100-22X18-4	Drum
S602600-28	EA/EB37128 L	5	1	262659-28	Support Shaft
S602600-28	EA/EB37128 L	3	1	326100-28X18-4	Drum