

# Operating Instructions

## Series TH9000 Spring Driven Hose Reels

Medium Pressure Model Numbers:

TH9200 OMPBW

TH9265 OMPBW



### Dimensions

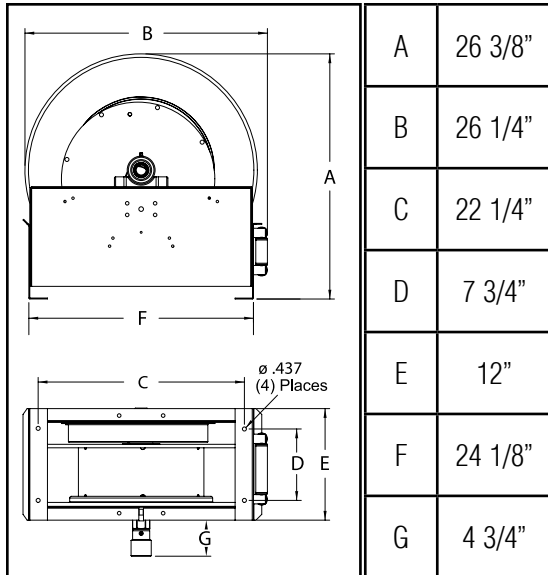

### SAFETY

1. Do not use reel at higher pressures or temperatures than listed on the back of this bulletin.
2. Remove all spring tension before beginning disassembly process.
3. Reel spring motor case is permanently sealed. Any attempt to remove the spring motor may cause serious injury.

#### INSTALLATION:

The swivel union is packed separately in the reel carton, use teflon tape to assure a satisfactory seal. A flexible hose connection must be used between the hose reel inlet and the source of supply to prevent possible misalignment and binding. Non flexible connections will void the warranty, pressure rating of inlet hose must be equal to or more than the pressure rating of the reel. Consult factory for proper spring when installing reels above 16 ft.

#### LUBRICATION:

Hose reel spring and bearings are factory lubricated and require no further lubrication.

#### REPLACING HOSE:

1. Wind spool flange clockwise-facing swivel-until spring is tight.
2. Back off three turns and latch.
3. Insert hose through roller guide.
4. Connect hose fitting to female outlet ell.

#### ADJUSTMENTS:

To adjust spring tension, add or remove wraps of hose from the spool, one wrap at a time until desired tension is obtained.

#### REPAIRS:

Extensive repairs should be performed only by an authorized serviceman or factory to avoid damage which may void your warranty. Remove all spring tension before beginning disassembly process.

#### MODIFICATION:

Hose latching mechanism can be removed for constant tension applications.

Form# 1243-1120 Rev: 8/2018

# Series TH9000 Spring Driven Hose Reels

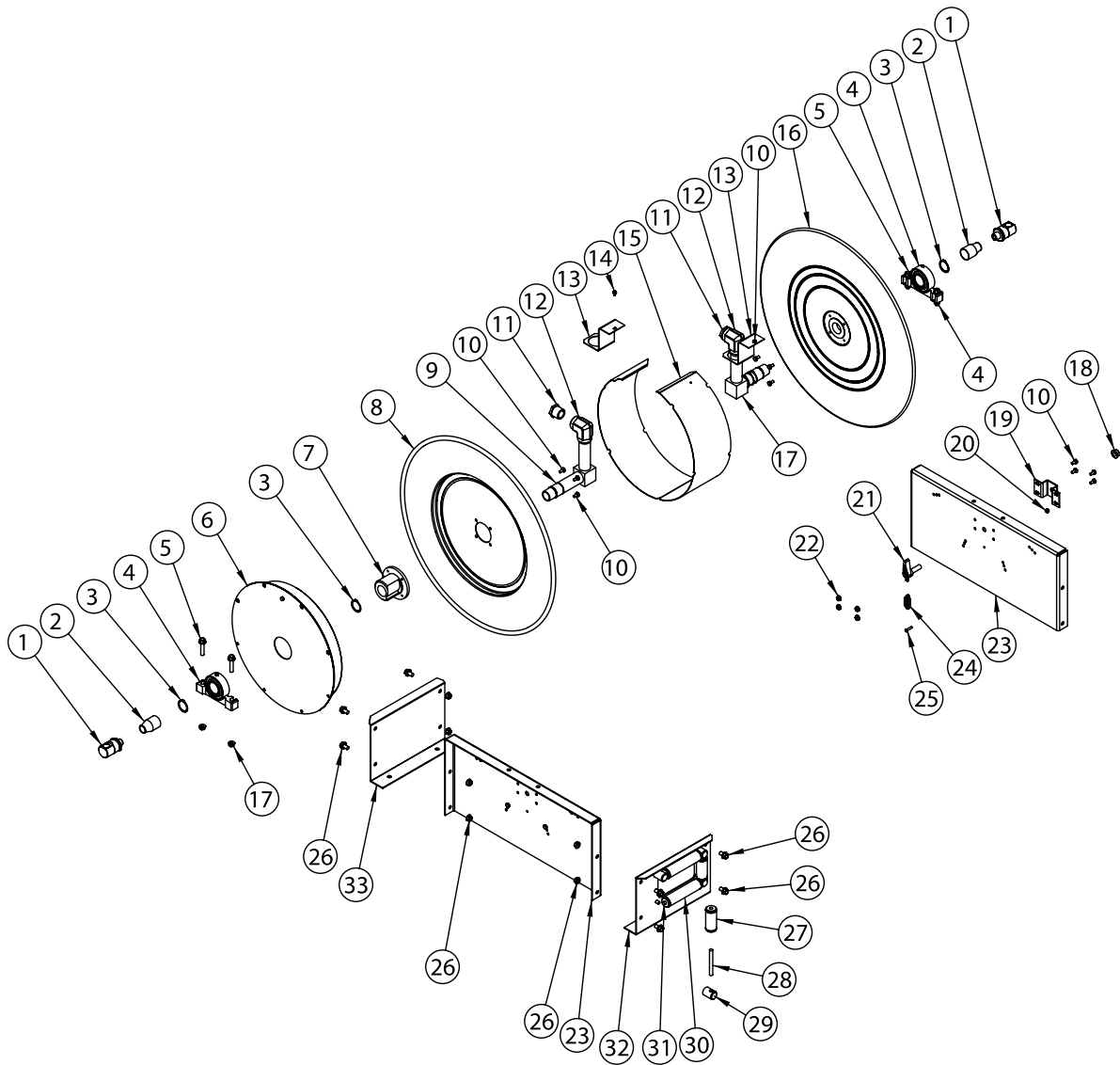

Item #	Part #	# Req	Description	Item #	Part #	# Req	Description	Item #	Part #	# Req	Description
3	S140-34	6	Snap Ring 1-3/8" I.D.	14	S32-136	2	Self Tapping Screw 10-24 x 3/8"	24	S260067-1	1	Latch Spring
4	S600416	2	Pillow Block Assembly	15	260948	1	Spool spacer	25	S393-2	1	Shoulder Screw 10-32 2A
5	S44-8	4	Machine Screw 3/8-16 x 1-3/4"	16	270007	1	Flange Disc	26	S44-2	8	Machine Screw 3/8-16 x 5/8"
6	600413-1	1	Spring Case Assembly	17	602364	1	Inlet Shaft	27	262436-2.968	2	Short Guide Roller
7	260888	1	Spring Arbor	18	S280-8	1	Hex Flange Nut 1/4-20	28	S270015	2	Short Guide Roller Pin
8	260898	1	Flange Sheave	19	260934	1	Latch Bracket	29	S270014	4	Guide Roller Post
7	260888	1	Spring Arbor	20	S82-15	1	Nyloc Nut 10-32	30	262436-5.468	2	Long Guide roller
8	260898	1	Flange Sheave	21	S600454	1	Latch Pawl Ass'y	31	S270016	2	Long Guide Roller Pin
10	S2-41	16	Hex Cap Screw 1/4-20 X 1/2"	22	S281-4	8	Hex Flange Nut 1/4-20 Whiz Loc	32	270011	1	Guide Roller Plate
13	270029	2	Hose Outlet Support	23	270009	2	Side Frame	33	270012	1	End Frame Support

Item #	Description	# Req	TH9200 OMPBW	TH9265 OMPBW
1	Swivel	2	S602033	S602033
2	Reducing Coupling	2	S290-5	S290-5
9	Inlet Shaft	1	602556	602556
11	Bushing 1" X 1/2"	2	S174-112	S174-112
12	90° EII 1"	2	270039	270039
--	Hose Assembly	--	None	600669-5
--	Bumper Stop	--	None	600522
--	Hose ID and length	--	None	1/2" x 65'
--	Working pressure	--	3000 PSI	2000 PSI
--	Max. temperature	--	210 °F	210 °F