

# Operating Instructions

## Series TB / TBL Tool Balancers

Model Numbers:

TBL 10    TBL 15    TBL 23



### Dimensions

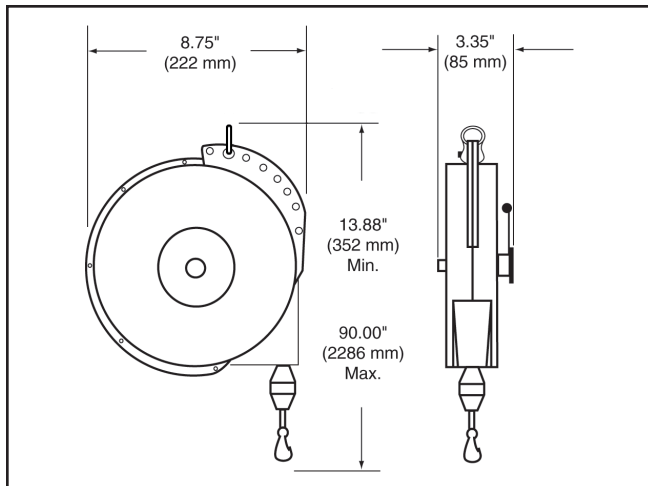

### **WARNING**

DO NOT allow spring to unwind in an uncontrolled manner. Doing so can result in damage to reel or personal injury.

DO NOT attempt to remove spring motor from its canister. Doing so can result in damage to reel or personal injury.

NOTE: To minimize wear on cable and cable guide, reel should be mounted directly over work area and, preferably, on a rolling trolley so that cable is pulled out as straight as possible during use.

### MOUNT REEL

1. Use clevis to hang reel in desired location. Be sure cotter pin is installed on clevis pin.
2. Attach optional safety chain to secondary hanger bracket or other overhead support. Do not use the same attachment point as used for the clevis. See figure 1.

**CAUTION:** To prevent reel fall should primary clevis mount fail, it is recommended that a safety chain be used from reel to a secure secondary support. Failure to use safety chain could result in personal injury.

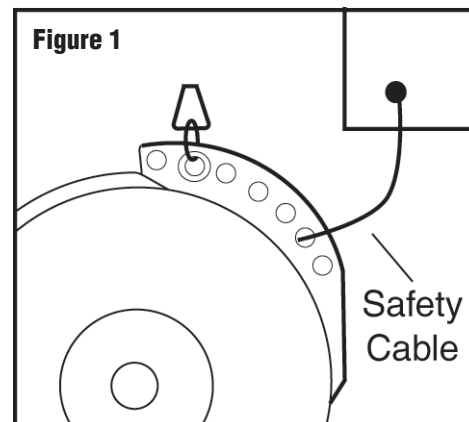

Form# 1269-1104 Rev: 01/2023

## ATTACHING LOAD

For most effective use of reel, tool (Figure 2) should be positioned at top of working range with no cable pulled off reel. Use overhang cables to achieve proper distance from reel to tool. Cable on reel should be used only to move tool within working range. To attach load (all components hung on reel), raise load to safety clip and attach. **DO NOT pull cable down to load.**

**CAUTION:** Always raise load to safety clip on cable reel. **DO NOT** pull reel cable down to load. Doing so can result in damage to reel or personal injury.

## TENSION ADJUSTMENT

Increase tension if reel will not completely rewind cable with load attached until bumper stop reaches guide.

1. Allow cable to retract as far as possible.
2. Place wrench on flats of shaft. Turn shaft counter-clockwise until cable stop reaches guide.

Decrease tension if load cannot easily be pulled down to desired height.

1. If reel is so equipped, turn ratchet lock to "OFF" (knob is located on side of reel).
2. Place wrench on flats of shaft.
3. Hold shaft firmly with wrench. Depress spring on opposite side of reel.
4. Allow shaft to turn SLOWLY in clockwise direction until desired tension is achieved. If shaft will not turn in clockwise direction UNASSISTED, reel is at minimum tension and further tension reduction should not be attempted.

## Optional Accessories

**261241** - Safety clip

**S602413** - Replacement bumper

**600603** - Safety cable (1 ft / 30.5 cm); nylon covered steel for 1-6 lbs models

**600604** - Safety chain (1 ft / 30.5 cm); steel link chain for 10-23 lbs models

**600605-3** - Overhang cable (3 ft / 91.5 cm)

**600605-5** - Overhang cable (5 ft / 152.4 cm)

Cables can be combined for added length.

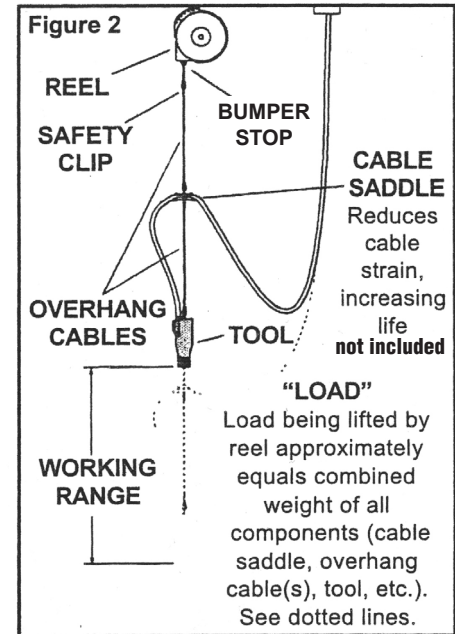

## RATCHET LOCK USE

If reel is equipped with ratchet lock ("TBL" models), engage by pulling cable out to desired position and letting it retract SLOWLY until lock engages. To release lock, quickly pull cable out a short distance and allow it to begin to retract - it operates like a window shade. Ratchet lock may be disengaged by turning knob on side of reel.

## REGULAR MAINTENANCE

Reel is factory lubricated for life. No additional lubrication is required.

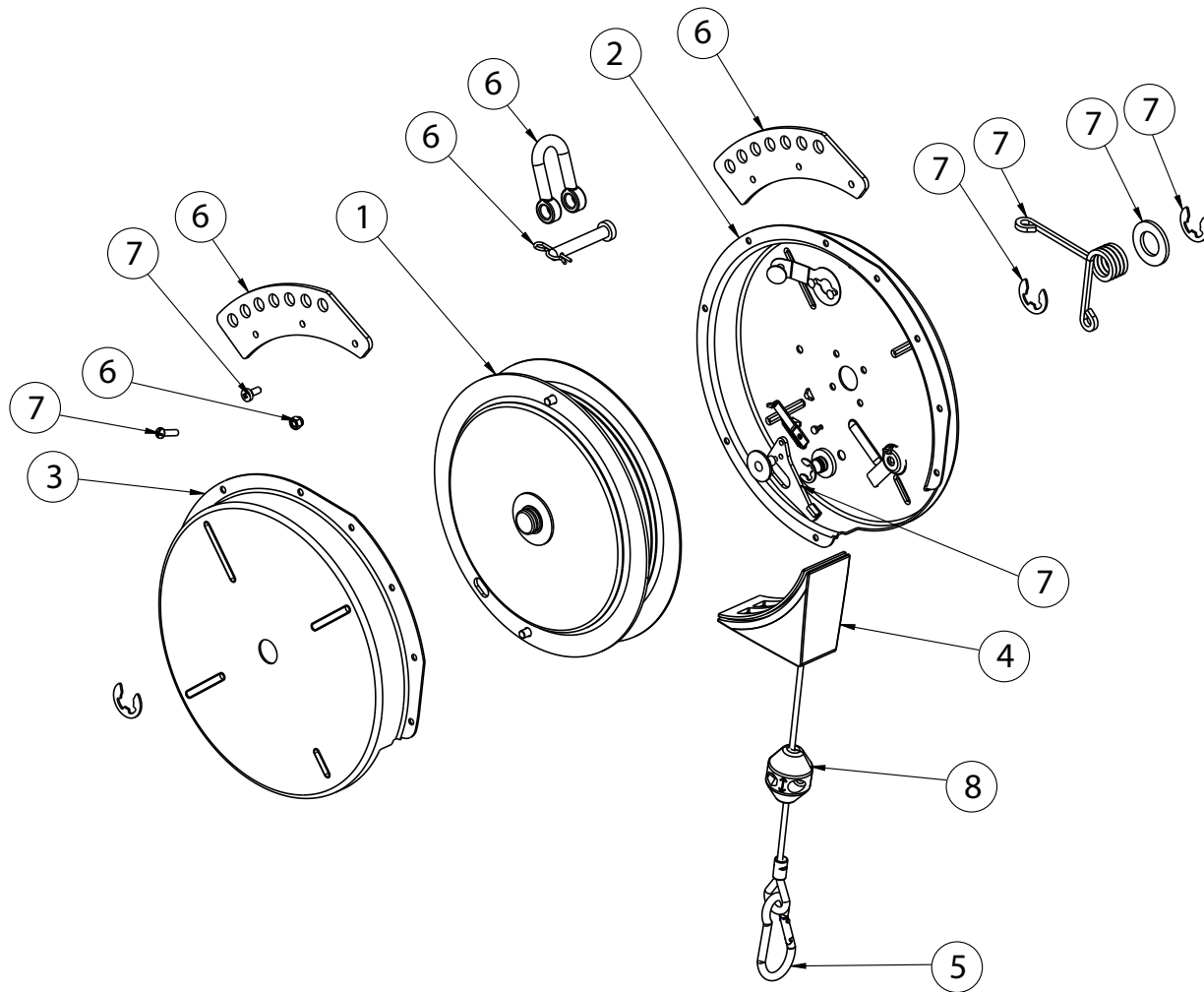

**Replacement parts available as kits only.**

#	KIT DESCRIPTION	TB 10	TBL 15	TBL 23
1	<b>Spring Motor Assembly:</b> Spring motor, spool, shaft and bushings in sealed container	K01-A	K01-B	K01-C
2	<b>RH Housing Assembly:</b> RH housing half, ratchet lock assembly	K02-A	K02-B	K02-B
3	<b>LH Housing Assembly:</b> LH housing half, nameplate	K03-A	K03-A	K03-A
4	<b>Cable Guide</b>	K04-A	K04-A	K04-A
5	<b>Cable Assembly:</b> Cable, safety clip, lockwasher-M4, hex nut-M4	K05-A	K05-A	K05-A
6	<b>Hanging Bracket Assembly:</b> Hanging bracket, clevis and clevis pin assembly, slotted machine screw M14 x 14mm (3), lockwasher-M4 (3), hex nut-M4(3)	K06-A	K06-A	K06-A
7	<b>Hardware Package:</b> Spacer, torsion spring, slotted machine screw M4 x 14mm (3), slotted machine screw M4 x 8mm (6), lockwasher-M4 (10), hex nut-M4 (10), retaining ring (3), shim, extension spring and ratchet lock assembly	K07-A	K07-A	K07-A
8	<b>Bumper Stop</b>	S602413	S602413	S602413