

Operating Instructions

Series CEA30000 Welding Cable Reels

Model Numbers:

CEA30006

CEA30012



Dimensions

	A	B	C	D	E
CEA30006	6"	9 3/4"	11"	15"	21"
CEA30012	12"	15 3/4"	17"	21"	27"

Four 1/2" diameter mounting holes

SAFETY

Personal injury and/or equipment damage may result if proper safety precautions are not observed.

- Ensure that only a qualified electrician installs/services this equipment.
- Ensure that power supply voltage does not exceed maximum voltage rating of reel.
- Ensure that reel is properly installed before connecting to power supply.
- Ensure that all electrical power is removed from reel before servicing.
- Check for frayed/broken wires before each use.
- Pull electrical cord from reel by grasping the electrical cord itself, not the work device.
- If an electrical malfunction should occur, remove power from reel immediately.

IMPORTANT

Read this manual carefully before installing, operating or servicing this equipment.

- Ensure that reel, electrical cable, and equipment being serviced are properly grounded. Use an ohmmeter to check ground continuity.
- If reel ceases to unwind or rewind, remove power immediately. Do not pull or jerk on electrical cable!
- Treat and respect the cable reel as any other piece of machinery, observing all common safety practices.

WARNING: Even low voltage can cause irreparable damage or death! Exercise extreme caution while operating or servicing this equipment.

WARNING: This reel is to be used for cable storage only! The entire length of cable must be unwound before use. Severe damage to the reel will result if the cable is energized while fully wound on the reel.

Form# 959-798 Rev: 7/2013

INSTALLATION INSTRUCTIONS

Ensure that only a qualified electrician installs/service this equipment. Observe applicable NEC, OSHA, and local codes when installing this equipment.

MOUNTING

Note: Ensure that the mounting surface is flat to prevent binding on reel after it is mounted.

1. Unpack and inspect reel for damage. Turn by hand to check for smooth operation. Check for completeness.
2. Two 1/2" diameter mounting holes are located at the base of each side support panel. Mount the reel using four (customer supplied) bolts (1), tightening them securely to ensure a solid, rigid attachment.

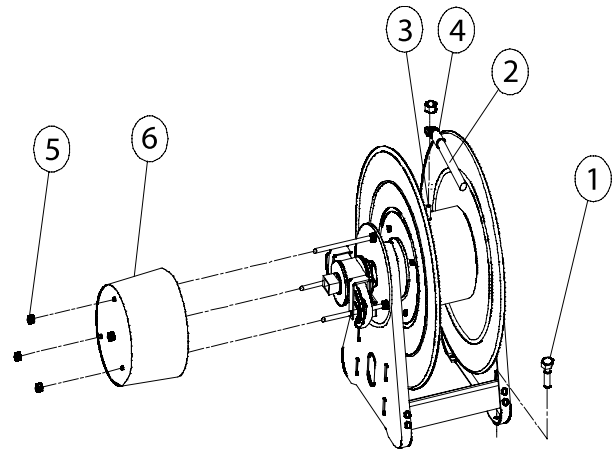

INSTALLING THE OUTPUT CABLE

1. Attach the output cable (2) to the mounting stud (3), using the supplied copper lug (4).

INSTALLING THE INPUT CABLE

1. Remove the three outer nuts (5) on the collector ring cover, and remove the cover (6).
2. Strip 1-1/8" of insulation from the input cable (7), and insert the input cable into the rubber grommet (8) on the collector ring cover.
3. Attach the bare wire of the input cable to the buss bar connection (9) located at the bottom of the collector ring.
4. Using an ohmmeter, check for ground faults.
5. Replace the collector ring cover. Be sure to insert the rubber grommet into the slot in the bottom of the cover.

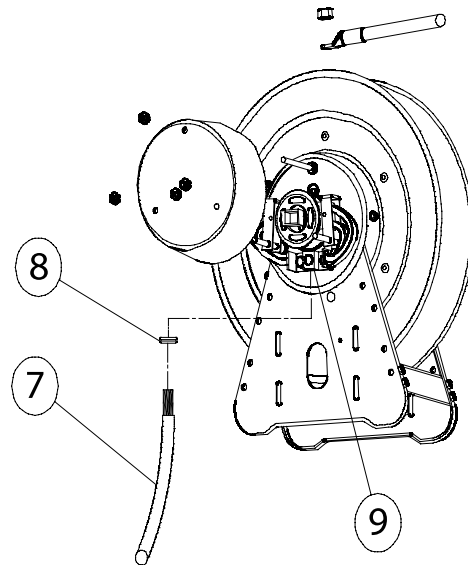

ADJUSTMENT PROCEDURES

1. Adjust reel drag by loosening or tightening set screw on hub casting.

NOTE: Refer all repairs for the collector ring assembly to the manufacturer.

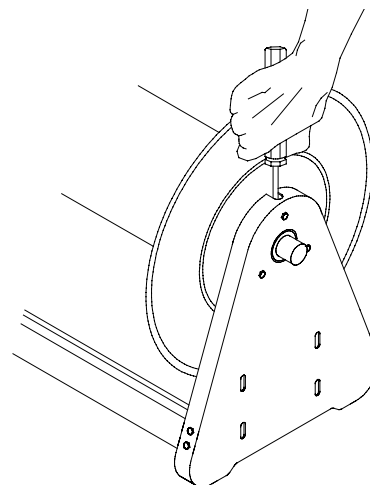

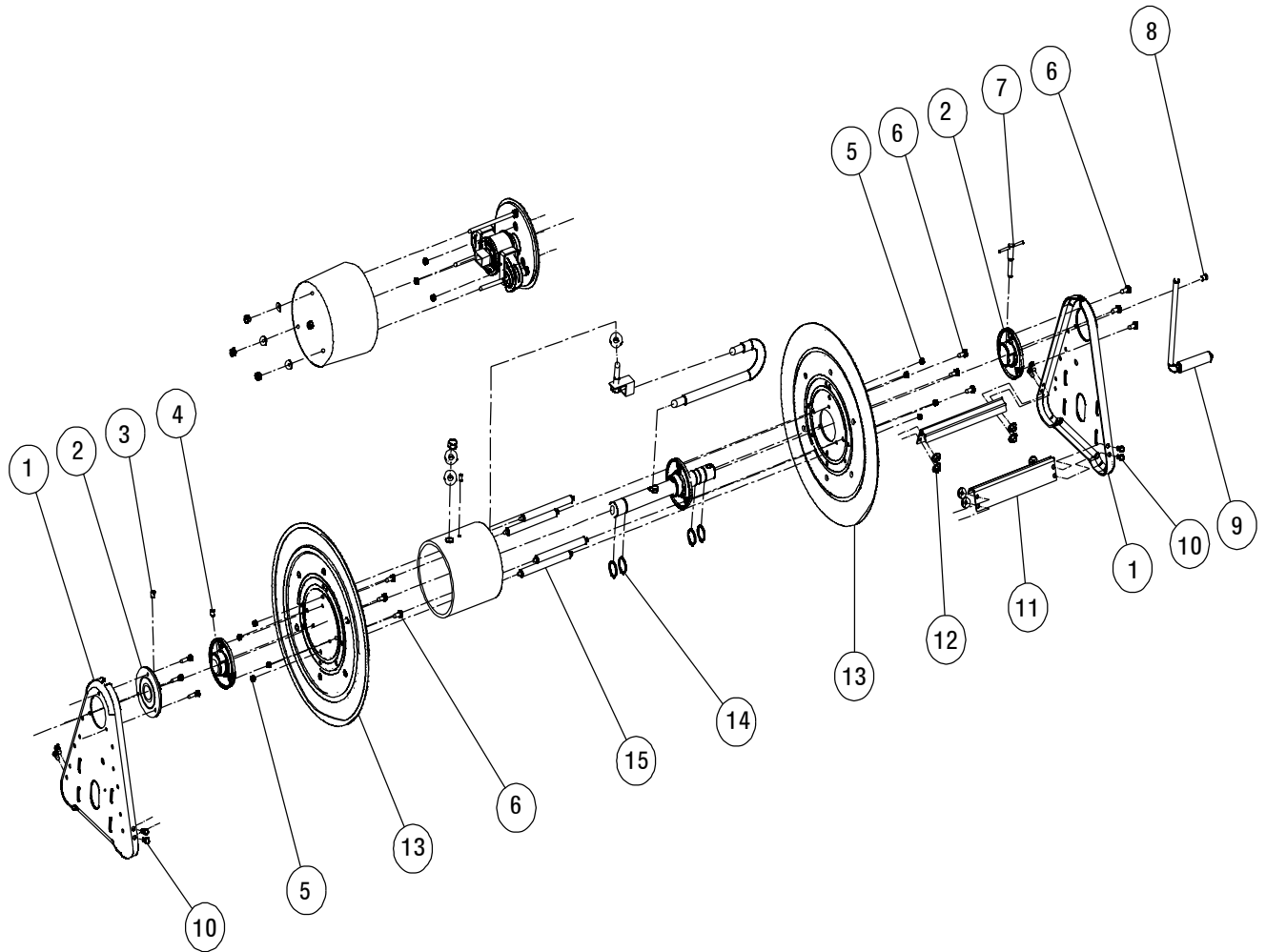

Item #	Description	Qty.	CEA30006	CEA30012
1	Side Frame	2	260403	260403
2	Hub & Bushing Assembly	4	S600640	S600640
3	Set Screw (Brass)	1	300099	300099
4	Set Screw	1	300006	300006
5	Nyloc Nut	8	S85-7	S85-7
6	Self-Tapping Screw	12	S317-31	S317-31
7	Lock Handle	1	S280109	S280109
8	Set Screw (Square Head)	1	300089	300089
9	Crank & Handle Assembly	1	S600102	S600102
10	Hex Screw (5/16-18 x 1/2")	8	S2-51	S2-51
11	Cross Brace	2	261501-1	261501-2
12	Lock Nut	8	300107	300107
13	Spool Flange	2	S260399-3	S260399-3
14	Snap Ring (1-1/4")	4	300007	300007
15	Tie Rod	4	260402-100	260402-200